

# Active bread cooling

PASSIVE BREAD COOLING IS A THING OF THE PAST. WHEN CONTROL OF THE COOLING PROCESS AND ITS PARAMETERS IS REQUIRED, ACTIVE COOLING IS A MUST. HEINEN FREEZING, VAREL, GERMANY, WILL BE INTRODUCING ITS ADVANCED EQUIPMENT AT IBA

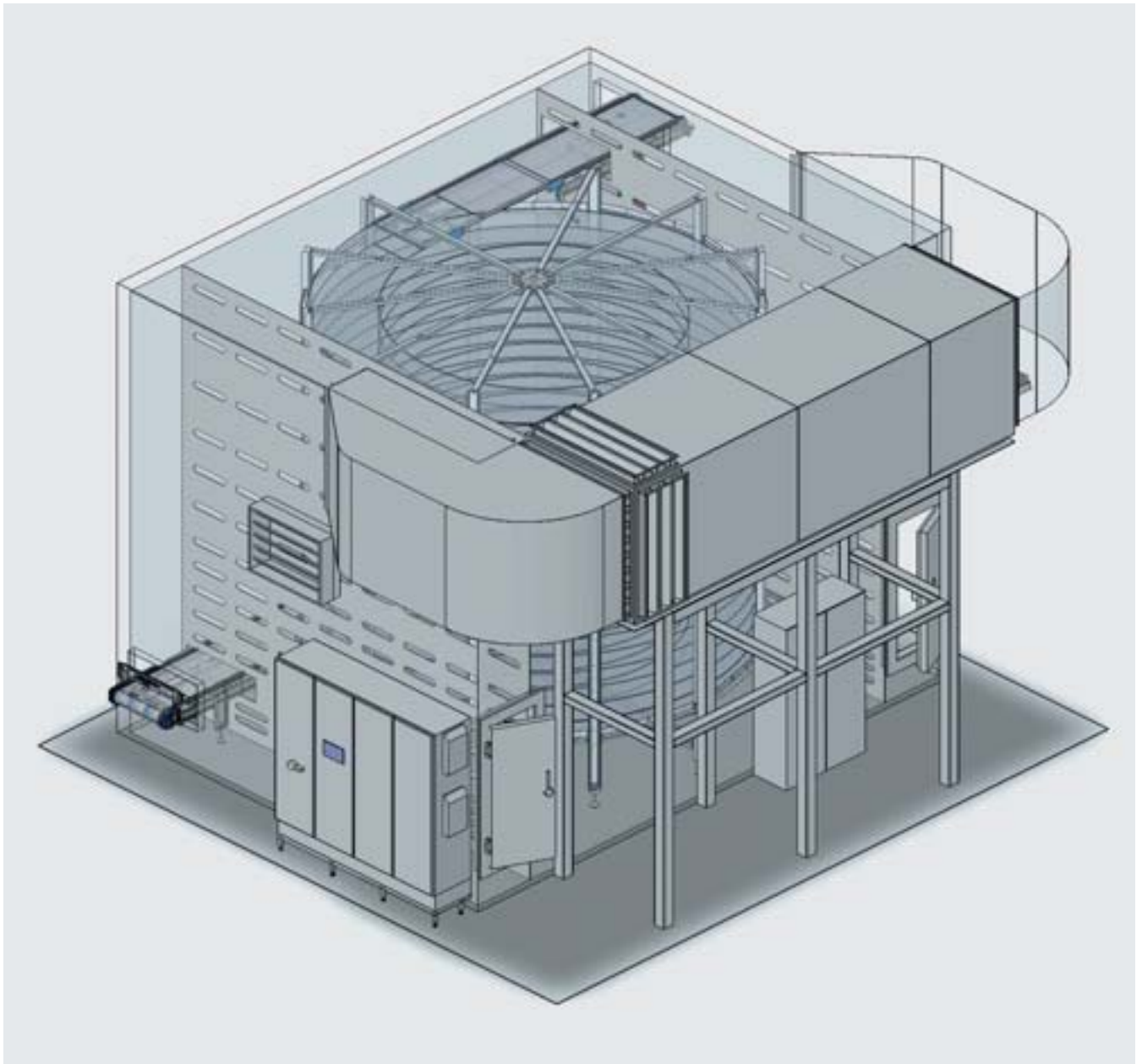

**+** They are a familiar sight – conveying belts of almost endless length on which baked bread loaves travel high above the production area close to the ceiling through the facility until the loaves are cooled down to a temperature where they can be sliced and packed. It is only the belt speed that can be controlled for this type of process with everything else, such as air temperature and humidity being dependent on the time of the year, the weather conditions and the processes happening down below in the production

and baking areas. This leads ultimately to a type of game with an unknown outcome in terms of water content of the product. Added to this, the hygienic conditions are also very questionable.

Product safety and consistent quality factors play a much more decisive role today with the result that the requirements for the cooling of bread loaves are on the rise. “Active cooling” is the magic word for those who cannot accept uncontrolled product losses and who want to be sure that the bread loaves at the

Our Industry Proven Pan Coating Technology has the  
**World's Longest Release Life & the  
World's Best Release Characteristics**  
**GUARANTEED**



**DuraShield Europe offers the most effective  
pan coating removal and recoating process in existence today.**

- Proprietary coating removal process does not degrade the strength or integrity of pan
- Exclusive nanotechnology provides unparalleled corrosion protection

**DuraShield coating consistently delivers more releases,  
sometimes twice the releases, than all other competitors worldwide.**

- Thousands of releases without recoating
- PFOA Free Fluoropolymer
- Excellent dough flow and bake characteristics

TÉL +33 (0)3 27 84 23 38  
[WWW.DURASHIELDEUROPE.COM](http://WWW.DURASHIELDEUROPE.COM)



Hall 9 / Stand G19



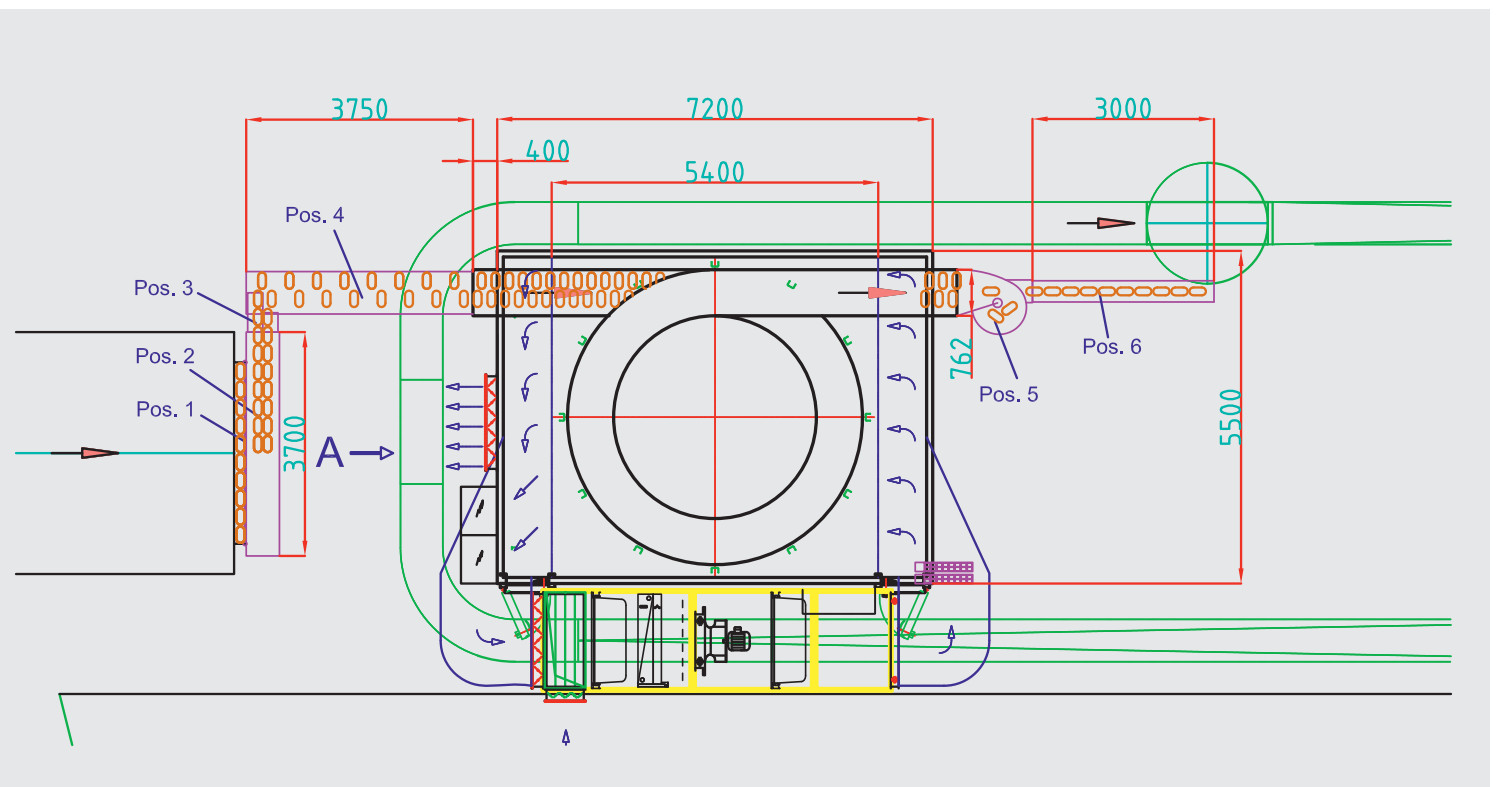

end of the cooling process have the temperature needed for the downstream slicing process.

The equipment designed and installed by Heinen Freezing is based on a stainless steel spiral conveying plant from its arctic series (see 3-D drawing).

Basically, spirals from 12 to maximal 32 levels on a drum can be used as needed. The maximum height of the product to be cooled is 180 mm. There are two different radius ratios available – normal and reduced radius. This provides for more flexibility in the design of the footprint, according to Jochen Hottinger, managing director at Heinen. “In general, such cooling equipment has to be integrated into existing production facilities where the space is often restricted.” Of course, the equipment is also available as a double tower spiral and, depending on the existing space, with an upwards or downwards direction of conveying and four different layouts where the in-feed and outlet sections are offset by 0°, 90°, 180° or 270°.

The process takes 30 to 240 minutes, depending on the requested end temperature, says Hottinger. During this time, filtered air flows horizontally through the spiral. The laminar air flow, which is introduced through slots to the inside of the tower, cools the products on the belt gently without drying them out.

The air velocity is less than one meter per second.

Prior to being introduced into the spiral, the air is filtered. The respective industrial filters can be F5, F7 or F9. Hottinger explains, “Of course, it is possible to refrain from this intense filtering, but nevertheless it is recommended. The filters provide a certain protection against microorganisms and spores entering and only require minor effort.” In general, the filters are replaced only once a year. A slight overpressure inside the housing prevents unfiltered air from en-

tering the cooling spiral. The overpressure can be controlled and determines the velocity and volume of the air exchange.

The air sucked in is either outside air or air from inside the production hall. A ventilation control supervises the mixture of both types of air so that, in general, no additional heating system is required. For higher temperatures in the summer, a cooling device is required and has already been integrated.

The air is not just filtered but also sterilized by UV rays and also humidified. For that, an ultrasonic humidifier or alternatively a high pressure atomizer is available.

In general, the temperature used to cool down the baked goods is in the range of +15 to + 25 °C depending on the specific product requirements. This prevents the drying-out of the products due to low temperatures. The humidity can also be set to the respective requirements of the product within the range of 55 to 75% RH. The water used to humidify the air has been treated via reverse osmosis and can be sterilized by UC-C rays, if desired.

An active cooling spiral as the one recently installed in a bread factory in Poland requires a footprint of 7 x 8 m and a height of 5 m. Equipment of this size is sufficient to cool down up to 1,600 bread loaves per hour within 90-120 minutes.

The drum of the spiral is completely open. Different from spiral freezers, there are no bottom and no inserted ceilings because the air flow should not be hindered and the products on the belt need to be flushed uniformly for improved cooling. Tower and spiral freezers can be completely cleaned with water.

A separate programmable air conditioning unit measures temperature, humidity and air velocity. +++

# The true in-store bakery ovens:

**IN-STORE  
RELIABLE  
USER-FRIENDLY  
PROFITABLE  
EASY-TO-LEARN  
PRODUCTIVE  
DURABLE  
STAINLESS  
ECONOMIC**



**S400**

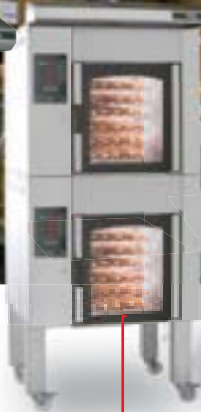

**S200**

All Sveba-Dahlen's ovens are built to meet with your demands on high productivity at low operating and maintenance costs. An investment that always gives you a fast pay off. In our product range you will find ovens adapted to bake everything from cookies to heavy loaves and rye bread – all of them reliable, easy-to-use, productive, durable, stainless and economic.

With our reliable and user-friendly in-store product range S200 and S400 you will have every basis needed for a profitable in-store bakery. We install the equipment, train your personell and makes it possible to start baking the same day your new oven arrives. With a complete service and support organisation we make sure your new oven always delivers. That's why we call them true in-store ovens.

**SVEBA  
DAHLIN**

*The baker's best friend*

[www.sveba-dahlen.com](http://www.sveba-dahlen.com)

Sveba-Dahlen AB, SE-518 32 Fristad  
Tel: +46 (0)33-15 15 00, Fax: +46 (0)33-15 15 99, [info@sveba-dahlen.se](mailto:info@sveba-dahlen.se)



Hall 16 / Stand A20



Sveba Dahlen Group



Scandinavian know-how – worldwide