

Ambassador of cultures

ED AND DAVID MAFOUD ARE CURRENTLY MANAGING A BAKERY FOUNDED BY THEIR GRAND-FATHER HASSAN IN 1930 AS A TYPICAL MOM+POP BAKERY IN BROOKLYN. THEY TURNED TO THE INDUSTRIAL PRODUCTION OF FLAT BREAD IN THE 1970S AND NOW THEY ARE WELL ESTABLISHED AS A NATIONAL BUSINESS

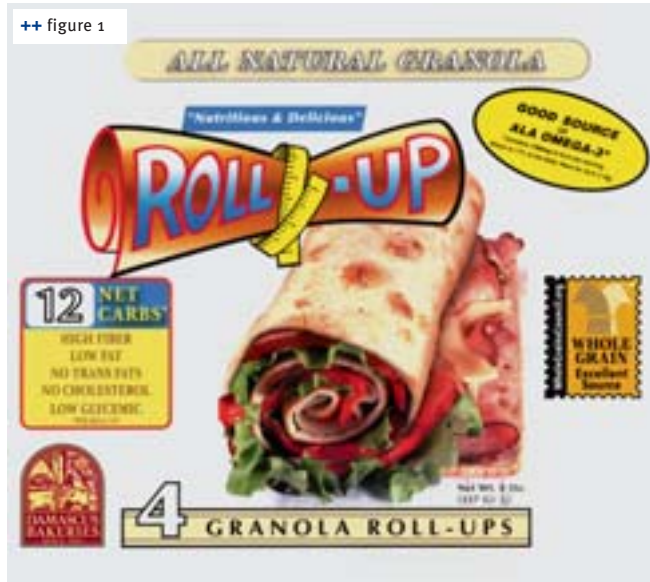

++ figures 1 + 2

Outright comparative advertising can be found on the roll-ups packagings aimed at low carb lovers. "With roll-ups, you get 2 oz of dough and 8 oz of filling. Filled wraps or bagels have only half the amount of filling to the same amount of dough. Therefore, we recommend: roll up your sandwich and roll down your weight."

Whole wheat roll-ups are thinly baked yeast-dough squares. Their flavor is superior to the rather bland wheat wraps because of the use of yeast and the special baking process.

++ figure 3

Fritsch IMPRESSA wrap line

+ Pita and lahvasch wraps are only two variations of flat bread. Ed and David Mafoud, who had their grandfather's bakery named after his hometown Damascus, are convinced that these flat breads are much more flavorful products compared to wheat tortillas which originated in Mexico and which have conquered their country now thanks to the increasing number of people from Latin America. In this respect, the Mafouds are also ambassadors of the Arabic bread culture in the US. They are successful ambassadors because 95% of their products produced in 7/24 shifts by 115 people (the entire staff is 130) are sold outside of New York. The weekly flour consumption is 400,000 lbs or almost 200 US tons / 181 metric tons. This amount will increase with the move of the production facility from the historical building underneath the Brook-

lyn Bridge into the facility in New Jersey, just outside the city limits of New York. Both current lines – one semi-automatic line for pita and one fully automatic flat bread line by Fritsch – are currently working at full capacity. They are used for the production of a wealth of different flat breads in various shapes and according to different recipes. When the production moved to the current location in 1979, pita bread was the key product. This flat bread consists mainly of a flexible crust and is popular because it can be filled with various salads, cold cuts and more. Today, this product accounts for only 10% of the total sales. It was replaced by the traditional lahvasch, a product now generating 25% of the turnover. Lahvasch is a very flat piece of yeast-dough which is baked very quickly (20-25 seconds) and very hot (800 °F/425 °C) on both sides. ▶

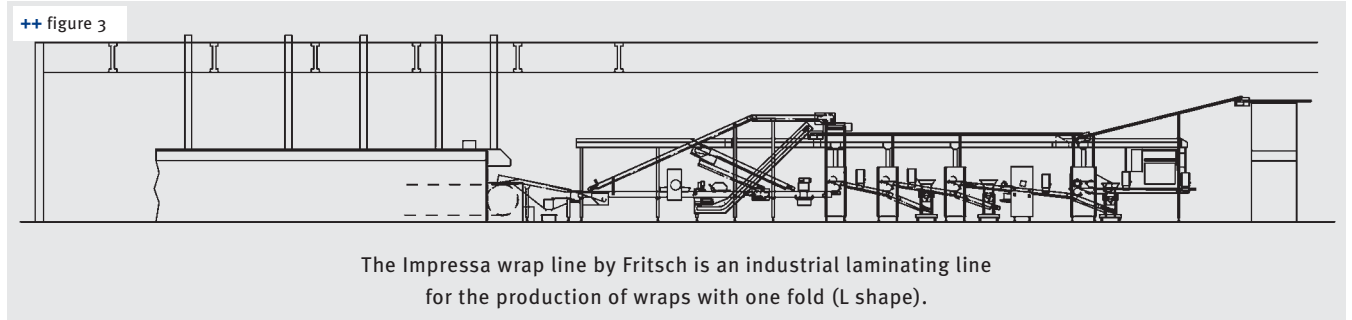

Even in the hottest ovens, we stay cool. Because the efficient handling and processing of raw materials has a decisive impact on the cost-effectiveness of production in industrial bakeries. Together with you, we develop and implement solutions for every stage of the process: intake and storage, proportioning, and weighing of dry and liquid products. System controls allow for customized recipes, and can easily be integrated into your production planning system. We'd be glad to speak with you about it, even if it means we have to get up extra early!



Passion from Grain to Bread.
Please visit us at IBA, Düsseldorf, Germany, hall 11, booth 11A15
from 3 – 9 October 2009

Bühler AG, Grain Milling, CH-9240 Uzwil, Switzerland, T +41 71 955 11 11, F +41 71 955 66 11
milling@buhlergroup.com, www.buhlergroup.com



The solution behind the solution.





++ figures 4 + 5 + 6
Damascus Bakeries shows in its advertising leaflets the variations available with flat bread: filled pita, pizza topping and others

When cooled down the wrap become flexible again. This bread originated in the Eastern Mediterranean region and is today one of the most important types of bread in the Middle and Far East as well as in the South-East Republics of the former Soviet Union. It is similar to the popular Turkish Dürüm. Damascus Bakeries produces lahvash as round wraps or in a square shape as a roll-up. The varieties include a whole meal multi grain wrap and a flax roll-up and many more differently flavored products. Par-baked flat bread is also sold as pizza crust. It needs only to be topped and heated. Another product is the so-called cracker bread which is par-baked flat bread slices that just have to be heated and dried in the household's oven.

One third of the products are delivered as fresh products; the other two thirds are frozen. Customers of the Damascus Bakeries include regional and national wholesalers. Added to that, the Mafouds supply their products to schools, airlines, restaurants, coffee shops, supermarkets and one internationally known snack producer.

David Mafoud explains the increasing popularity of the Arabic specialty products with the increasing awareness in the nutrition field. "Our flat breads and roll-ups are popular amongst those consumers watching their carbohydrate



intake and the glycemic index of the products. People do not want to eliminate carbohydrates completely from their diet but rather control them. This makes our products look good because the ratio between dough and filling is much better than with tortillas for example." In particular, the square wraps are easier to roll up than tortillas. Added to that, the bread tastes good. It is popular amongst children and teenagers and mothers who are concerned about their children's diet. They use the flat bread for sandwiches, pizza or panini. The Mafouds are placing great expectations on their latest development, gluten-free flat bread. Today, the majority of the 12 different flat bread products are made on a Fritsch line on which the punched out dough pieces travel directly into the oven. Ed Mafoud explains, "This new line (Damascus has purchased another line from Fritsch) will be equipped with a second satellite roller and a second cross roller. It will also have a proofing section so that we can make pizza crusts and square pita bread in addition to the other flat breads." The new production facility will eventually house five production lines and a spacious development center. The Mafoud message has not yet reached every corner of the country and there are still many markets to be conquered. +++